

Vacuum

Solution

Htc leading the new future for vacuum

2020

08 ACCESSORIES

ANSI, JIS, DIN Flange	8-2
ANSI ASA Blank	8-6
Welding Bellows Parts	8-8
Electrical Feedthrough	8-9
Sapphire viewport	8-12
Tempered Glass Viewport	8-13
CaF ₂ Viewport-KF	8-14
Sapphire Viewport	8-15
Magnetic Fluid Feedthrough	8-16
Molecular Sieve	8-23
Inline LN ₂ Cold Trap	8-24
Exhaust Filter	8-24



ACCESSORIES

➔ ANSI,JIS,DIN Flange

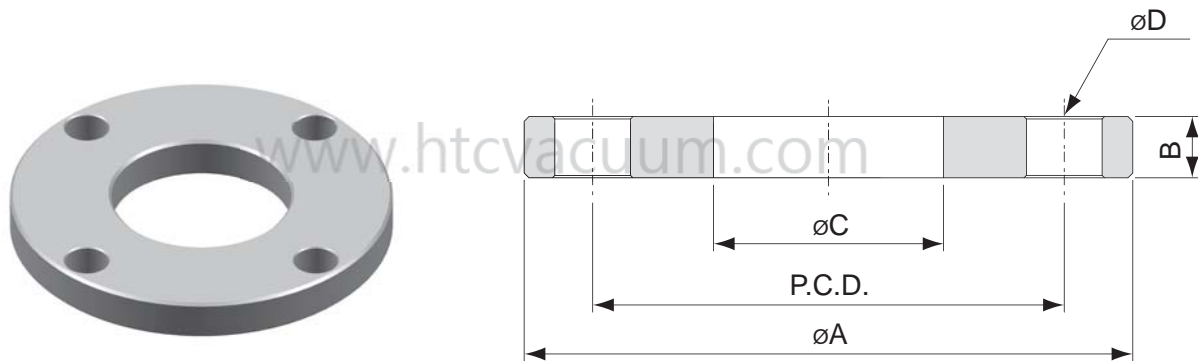

ANSI Flange(150LB)

Model No.	A	B	C	D*No.	Nominal	P.C.D.	Parts No.
ANSI150-350-050	3 1/2	7/16	0.88	5/8*4	1/2	2 3/8	156301A43
ANSI150-388-075	3 7/8	1/2	1.09	5/8*4	3/4	2 3/4	156302A53
ANSI150-426-100	4 1/4	9/16	1.36	5/8*4	1	3 1/8	156303A63
ANSI150-463-125	4 5/8	5/8	1.70	5/8*4	1 1/4	3 1/2	156323A73
ANSI150-500-150	5	11/16	1.95	5/8*4	1 1/2	3 7/8	156305A83
ANSI150-600-200	6	3/4	2.44	3/4*4	2	4 3/4	156306A93
ANSI150-700-250	7	7/8	2.94	3/4*4	2 1/2	5 1/2	156307B13
ANSI150-750-300	7 1/2	15/16	3.57	3/4*8	3	6	156308B23
ANSI150-850-350	8 1/2	15/16	4.07	3/4*8	3 1/2	7	156324B33
ANSI150-900-400	9	15/16	4.57	3/4*8	4	7 1/2	156309B43
ANSI150-1000-500	10	15/16	5.66	7/8*8	5	8 1/2	156310B53
ANSI150-1100-600	11	1	6.72	7/8*8	6	9 1/2	156311B63
ANSI150-1350-800	13 1/2	1 1/8	8.72	7/8*8	8	11 3/4	156313B73

Note:

- All dimensions shown on this page are in inch.
- Material : 304 Stainless Steel.



JIS Flange(5kg/cm²)

Model No.	A	B	C	D*No.	Nominal	P.C.D.	Parts No.
JIS5-075-010	75	9	17.8	12*4	10	55	157200AC3
JIS5-080-015	80	9	22.2	12*4	15	60	157201AD3
JIS5-085-020	85	10	27.7	12*4	20	65	157202AE3
JIS5-095-025	95	10	34.5	12*4	25	75	157203AF3
JIS5-115-032	115	12	43.2	15*4	32	90	157223AG3
JIS5-120-040	120	12	49.1	15*4	40	95	157205AH3
JIS5-130-050	130	14	61.1	15*4	50	105	157206AJ3
JIS5-155-065	155	14	77.1	15*4	65	130	157207AK3
JIS5-180-080	180	14	90.0	19*4	80	145	157208AL3
JIS5-190-090	190	14	102.6	19*4	90	155	157224AM3
JIS5-200-100	200	16	115.4	19*8	100	165	157209AN3
JIS5-235-125	235	16	141.2	19*8	125	200	157210AP3
JIS5-265-150	265	18	166.6	19*8	150	230	157211AQ3
JIS5-300-175	300	18	192.1	23*8	175	260	157225AU3
JIS5-320-200	320	20	218.0	23*8	200	280	157213AR3

JIS Flange(10kg/cm²)

Model No.	A	B	C	D*No.	Nominal	P.C.D.	Parts No.
JIS10-090-010	90	12	17.8	15*4	10	65	157400AC3
JIS10-095-015	95	12	22.2	15*4	15	70	157401AD3
JIS10-100-020	100	14	27.7	15*4	20	75	157402AE3
JIS10-125-025	125	14	34.5	19*4	25	90	157403AF3
JIS10-135-032	135	16	43.2	19*4	32	100	157423AG3
JIS10-140-040	140	16	49.1	19*4	40	105	157405AH3
JIS10-155-050	155	16	61.1	19*4	50	120	157406AJ3
JIS10-175-065	175	18	77.1	19*4	65	140	157407AK3
JIS10-185-080	185	18	90.0	19*8	80	150	157408AL3
JIS10-195-090	195	18	102.6	19*8	90	160	157424AM3
JIS10-210-100	210	18	115.4	19*8	100	175	157409AN3
JIS10-250-125	250	20	141.2	23*8	125	210	157410AP3
JIS10-280-150	280	22	166.6	23*8	150	240	157411AQ3
JIS10-305-175	305	22	192.1	23*12	175	265	157425AU3
JIS10-330-200	330	22	218.0	23*12	200	290	157413AR3

Note: * Material : 304 Stainless Steel.

DIN Flange(Nominal Pressure 6)

Model No.	A	B	C	D*No.	Nominal	P.C.D.	Parts No.
DIN6-075-010	75	12	17.7	11.5*4	10	50	158200A33
DIN6-080-015	80	12	21.8	11.5*4	15	55	158201A43
DIN6-090-020	90	14	27.4	11.5*4	20	65	158202A53
DIN6-100-025	100	14	34.2	11.5*4	25	75	158203A63
DIN6-120-032	120	16	42.9	14*4	32	90	158203A73
DIN6-130-040	130	16	48.8	14*4	40	100	158205A83
DIN6-140-050	140	16	60.8	14*4	50	110	158206A93
DIN6-160-065	160	16	76.6	14*4	65	130	158207B13
DIN6-190-080	190	18	89.4	18*4	80	150	158208B23
DIN6-210-100	210	18	114.8	18*4	100	170	158209B43
DIN6-240-125	240	20	140.2	18*8	125	200	158210B53
DIN6-265-150	265	20	168.8	18*8	150	225	158211B63
DIN6-320-200	320	22	220.1	18*8	200	280	158213B73

DIN Flange(Nominal Pressure 10)

Model No.	A	B	C	D*No.	Nominal	P.C.D.	Parts No.
DIN10-090-010	90	14	17.7	14*4	10	60	158400A33
DIN10-095-015	95	14	21.8	14*4	15	65	158401A43
DIN10-105-020	105	16	27.4	14*4	20	75	158402A53
DIN10-115-025	115	16	34.2	14*4	25	85	158403A63
DIN10-140-032	140	16	42.9	18*4	32	100	158423A73
DIN10-150-040	150	16	48.8	18*4	40	110	158405A83
DIN10-165-050	165	18	60.8	18*4	50	125	158406A93
DIN10-185-065	185	18	76.6	18*4	65	145	158407B13
DIN10-200-080	200	20	89.4	18*4	80	160	158408B23
DIN10-220-100	220	20	114.8	18*8	100	180	158409B43
DIN10-250-125	250	22	140.2	18*8	125	210	158410B53
DIN10-285-150	285	22	168.8	23*8	150	240	158411B63
DIN10-340-200	340	24	220.1	23*8	200	295	158413B73

Note: * Material : 304 Stainless Steel.



ANSI, JIS, DIN Flange

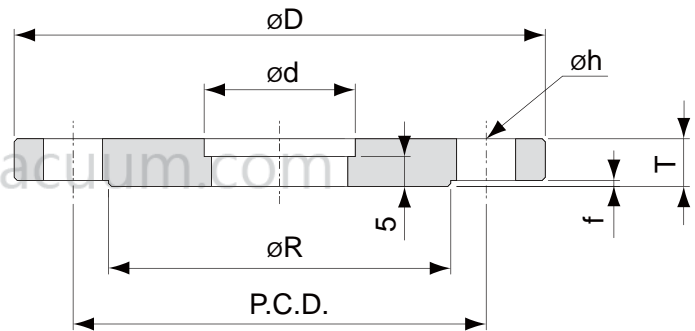

VF Flange (JIS B 2290_1968)

Model No.	ØD	Ød	f	Øh*No.	ØR	T	P.C.D.	Parts No.
VF20A	80	19.3	1	10*4	48	8	60	157502093
VF25A	90	25.6	1	10*4	58	8	70	157503113
VF40A	105	38.3	1	10*4	72	10	85	157505133
VF50A	120	51	1	10*4	88	10	100	157506143
VF80A	160	76.8	2	12*4	120	12	135	157508163
VF100A	185	102.2	2	12*8	145	12	160	157509183
VF150A	235	152.9	2	12*8	195	12	210	157511203
VF200A	300	203.7	2	15*8	252	16	270	157513213

Note: • Material : 304 Stainless Steel.

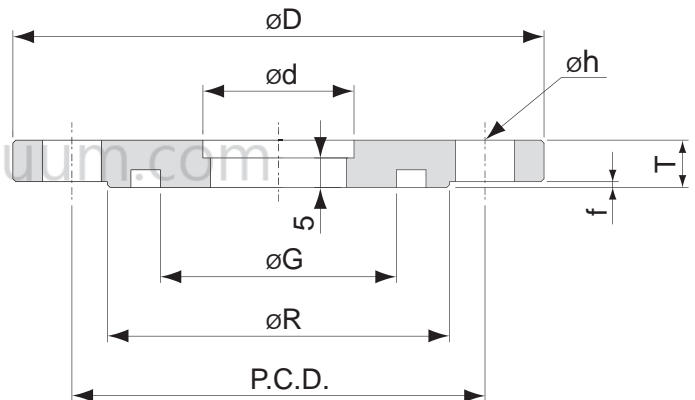

VG Flange (JIS B 2290_1968)

Model No.	ØD	Ød	f	ØG	Øh*No.	ØR	T	P.C.D.	Parts No.
VG20A	80	19.3	1	34	10*4	48	8	60	157602093
VG25A	90	25.6	1	40	10*4	58	8	70	157603113
VG40A	105	38.3	1	55	10*4	72	10	85	157605133
VG50A	120	51	1	70	10*4	88	10	100	157606143
VG80A	160	76.8	2	100	12*4	120	12	135	157608163
VG100A	185	102.2	2	120	12*8	145	12	160	157609183
VG150A	235	152.9	2	175	12*8	195	12	210	157611203
VG200A	300	203.7	2	225	15*8	252	16	270	157613213

Note: • Material : 304 Stainless Steel.



➔ ANSI ASA Blank

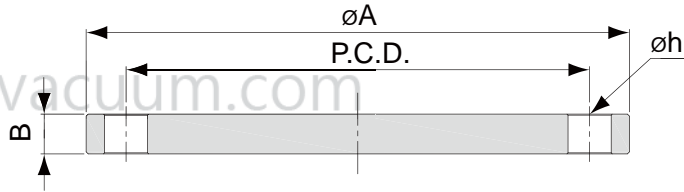
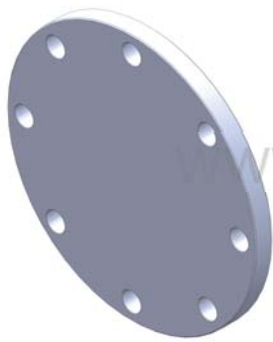

Model No.	ANSI size	A	B	h*No	P.C.D.	Parts No.
ASA4B	1	108(4.25)	12.7	15.8*4	79.4	156A03003
ASA5B	1.5	127(5)	12.7	15.8*4	98.4	156A05003
ASA6B	2	152.4(6)	12.7	19.0*4	120.6	156A06003
ASA7B	3	190.5(7.5)	12.7	19.0*4	152.4	156A08003
ASA9B	4	228.6(9)	12.7	19.0*8	190.5	156A09003
ASA11B	6	279.4(11)	19	20.6*8	241.3	156A11003
ASA13B	8	342.9(13.5)	19	20.6*8	298.5	156A13003
ASA16B	10	406.4(16)	25.4	20.6*12	362	156A14003
ASA19B	12	482.6(19)	27	25.4*12	431.8	156A15003

Note: • Material : 304 Stainless Steel.

➔ ANSI ASA Blank

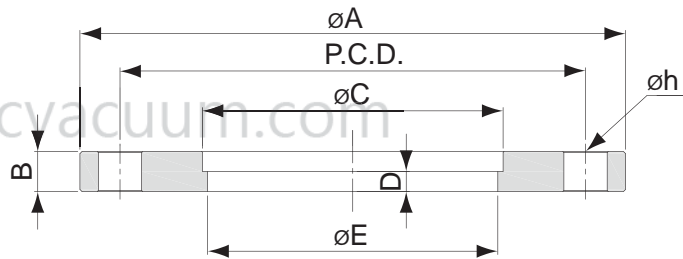

Model No.	ANSI size	A	B	C	D	E	h*No	P.C.D.	Parts No.
ASA4B25	1	108(4.25)	12.7	25.7	6.35	23.4	15.8*4	79.4	156C03113
ASA5B38	1.5	127(5)	12.7	38.4	6.35	36	15.8*4	98.4	156C05133
ASA6B51	2	152.4(6)	12.7	51	6.35	48.6	19.0*4	120.6	156C06143
ASA7B76	3	190.5(7.5)	12.7	76.8	6.35	73	19.0*4	152.4	156C08163
ASA9B102	4	228.6(9)	12.7	102.2	6.35	98.4	19.0*8	190.5	156C09183
ASA11B153	6	279.4(11)	19	152.9	9.5	147.9	20.6*8	241.3	156C11203
ASA13B204	8	342.9(13.5)	19	203.7	9.5	198.9	20.6*8	298.5	156C13213
ASA16B255	10	406.4(16)	25.4	254.5	12.7	249.5	20.6*12	362	156C14223
ASA19B305	12	482.6(19)	27	305.3	13.5	298.5	25.4*12	431.8	156C15233

Note: • Material : 304 Stainless Steel.



ANSI ASA Blank with O-ring Groove

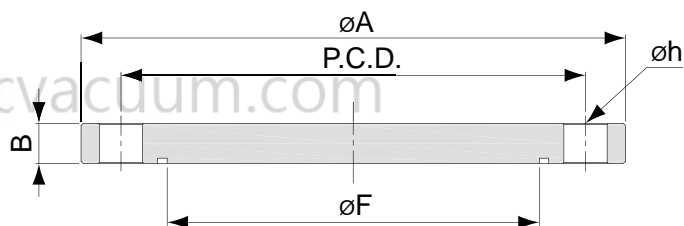
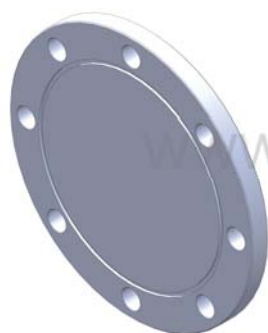

Model No.	ANSI size	A	B	F	h*No	P.C.D.	Parts No.
ASA4GB	1	108(4.25)	12.7	47.5	15.8*4	79.4	156E03003
ASA5GB	1.5	127(5)	12.7	63.5	15.8*4	98.4	156E05003
ASA6GB	2	152.4(6)	12.7	88.9	19.0*4	120.6	156E06003
ASA7GB	3	190.5(7.5)	12.7	117.6	19.0*4	152.4	156E08003
ASA9GB	4	228.6(9)	12.7	152.8	19.0*8	190.5	156E09003
ASA11GB	6	279.4(11)	19	203.8	20.6*8	241.3	156E11003
ASA13GB	8	342.9(13.5)	19	254.8	20.6*8	298.5	156E13003
ASA16GB	10	406.4(16)	25.4	306	20.6*12	362	156E14003
ASA19GB	12	482.6(19)	27	382.5	25.4*12	431.8	156E15003

Note: • Material : 304 Stainless Steel.

ANSI ASA Flange with O-ring Groove

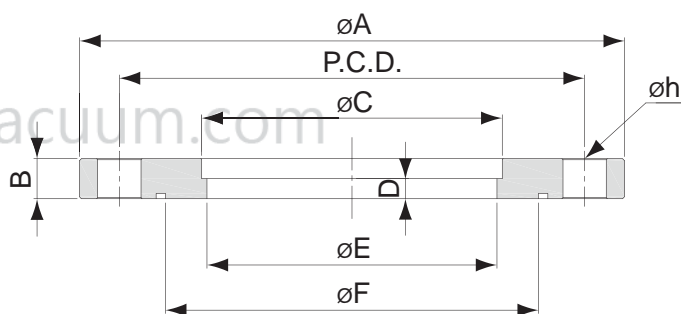

Model No.	ANSI size	A	B	C	D	E	F	h*No	P.C.D.	Parts No.
ASA4GB25	1	108(4.25)	12.7	25.7	6.35	23.4	47.5	15.8*4	79.4	156G03113
ASA5GB38	1.5	127(5)	12.7	38.4	6.35	36	63.5	15.8*4	98.4	156G05133
ASA6GB51	2	152.4(6)	12.7	51	6.35	48.6	88.9	19.0*4	120.6	156G06143
ASA7GB76	3	190.5(7.5)	12.7	76.8	6.35	73	117.6	19.0*4	152.4	156G08163
ASA9GB102	4	228.6(9)	12.7	102.2	6.35	98.4	152.8	19.0*8	190.5	156G09183
ASA11GB153	6	279.4(11)	19	152.9	9.5	147.9	203.8	20.6*8	241.3	156G11203
ASA13GB204	8	342.9(13.5)	19	203.7	9.5	198.9	254.8	20.6*8	298.5	156G13213
ASA16GB255	10	406.4(16)	25.4	254.5	12.7	249.5	306	20.6*12	362	156G14223
ASA19GB305	12	482.6(19)	27	305.3	13.5	298.5	382.5	25.4*12	431.8	156G15233



Welding Bellows Parts



Application

- Semiconductor Equipments
- Accumulators
- Actuators / Pistons
- Aneroids
- Bean Lines
- Connectors
- Couplings (Flexible)
- Couplings
- Expansion (Torque)
- Dampening Devices Joints
- Feed Throughs
- Fluid Shock Absorbers
- Fuel Drains
- Gas Lines
- Gate Valves
- Kiss Seals
- Leak Detectors
- Lifters
- Mechanical Shaft Seals
- Orientors
- Pressure Sensors
- Pressure Switches
- Pressure Transducers
- Pumps / Compressors
- Reservoirs
- Shielding Devices
- Slit Valves
- Temperature Sensors
- Valve Stem Seals
- Vibration Dampeners
- Volume Compensators
- Wafer Compensators
- X-Y-Z Manipulators

Electrical Feedthrough



1. High Machining Accuracy
2. Temperature Range : -100°C to 450°C
3. The Maximun Transferable Voltage is Up to 100kV
4. Customization Available Upon Request

KF Electrical Feedthrough

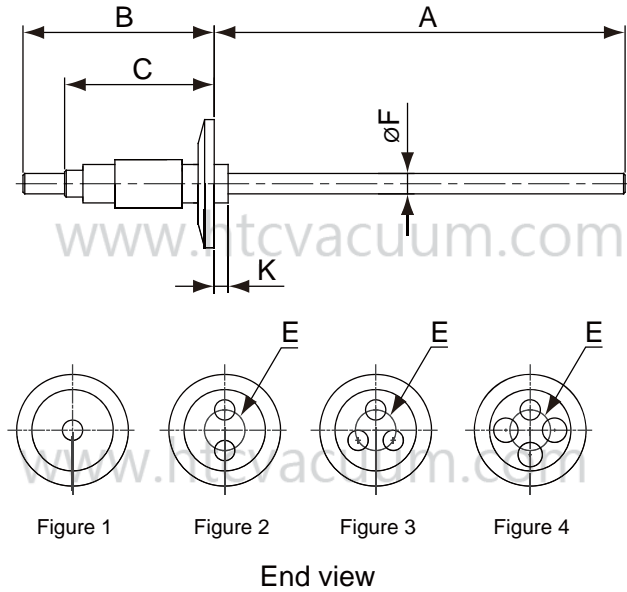
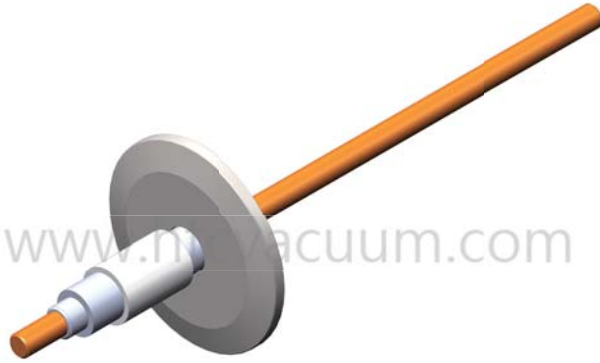

Model No.	Flange	No. Pins	Conductor Material	Voltage (kV)	Current (A)	Figure	Part No.
PFA01171QF	KF16	1	OFHC	5	180	1	1000FF030025
PFA01173QF	KF16	1	304 S.S.	5	7	1	1000FF030026
PFA01181QF	KF40	1	OFHC	5	180	1	1000FF030027
PFA01183QF	KF40	1	304 S.S.	5	7	1	1000FF030028
PFA01141QF	KF40	2	OFHC	5	180	2	1000FF030029
PFA01143QF	KF40	2	304 S.S.	5	7	2	1000FF030030
PFA01151QF	KF40	3	OFHC	5	180	3	1000FF030031
PFA01153QF	KF40	3	304 S.S.	5	7	3	1000FF030032
PFA01161QF	KF50	4	OFHC	5	180	4	1000FF030004
PFA01163QF	KF50	4	304 S.S.	5	7	4	1000FF030033

Model No.	A	B	C	K	E	F	Part No.
PFA01171QF	118	66	40.6	5.8	---	6.35	1000FF030025
PFA01173QF	118	66	40.6	5.8	---	6.35	1000FF030026
PFA01181QF	104.6	79.5	54	---	---	6.35	1000FF030027
PFA01183QF	104.6	79.5	54	---	---	6.35	1000FF030028
PFA01141QF	104.6	79.5	54	---	19.05	6.35	1000FF030029
PFA01143QF	104.6	79.5	54	---	19.05	6.35	1000FF030030
PFA01151QF	104.6	79.5	54	---	24	6.35	1000FF030031
PFA01153QF	104.6	79.5	54	---	24	6.35	1000FF030032
PFA01161QF	104.6	79.5	54	---	24	6.35	1000FF030004
PFA01163QF	104.6	79.5	54	---	24	6.35	1000FF030033

Note: All listed flanges are 304 S.S., other material could be used on request.



CF Electrical Feedthrough

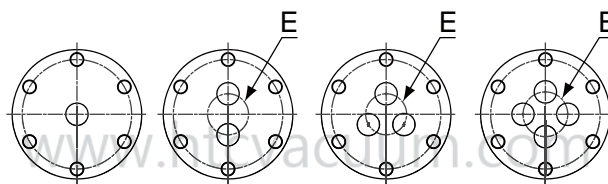
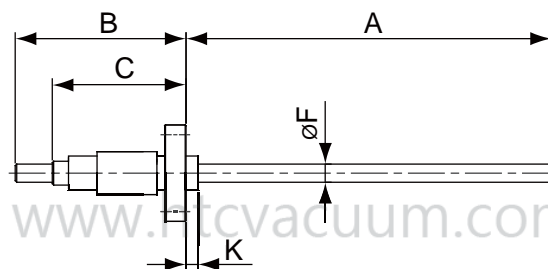

Figure 1 Figure 2 Figure 3 Figure 4

End view

Model No.	Flange	No. Pins	Conductor Material	Voltage (kV)	Current (A)	Figure	Part No.
PFA00491CF	CF16	1	OFHC	5	180	1	1000FF030034
PFA00493CF	CF16	1	304 S.S.	5	7	1	1000FF030035
PFA01131CF	CF35	1	OFHC	5	180	1	1000FF030005
PFA01133CF	CF35	1	304 S.S.	5	7	1	1000FF030036
PFA00651CF	CF35	2	OFHC	5	180	2	1000FF030014
PFA00653CF	CF35	2	304 S.S.	5	7	2	1000FF030037
PFA00641CF	CF35	3	OFHC	5	180	3	1000FF030038
PFA00643CF	CF35	3	304 S.S.	5	7	3	1000FF030039
PFA00631CF	CF35	4	OFHC	5	180	4	1000FF030040
PFA00633CF	CF35	4	304 S.S.	5	7	4	1000FF030041

Model No.	A	B	C	K	E	F	Part No.
PFA00491CF	116.3	67.8	42.4	3.6	---	6.35	1000FF030034
PFA00493CF	116.3	67.8	42.4	3.6	---	6.35	1000FF030035
PFA01131CF	103.4	80.8	55.4	---	---	6.35	1000FF030005
PFA01133CF	103.4	80.8	55.4	---	---	6.35	1000FF030036
PFA00651CF	103.4	80.8	55.4	---	19.05	6.35	1000FF030014
PFA00653CF	103.4	80.8	55.4	---	19.05	6.35	1000FF030037
PFA00641CF	103.4	80.8	55.4	---	24	6.35	1000FF030038
PFA00643CF	103.4	80.8	55.4	---	24	6.35	1000FF030039
PFA00631CF	103.4	80.8	55.4	---	24	6.35	1000FF030040
PFA00633CF	103.4	80.8	55.4	---	24	6.35	1000FF030041

Note: All listed flanges are 304 S.S, other material could be used on request.



☞ Sapphire viewport



A sapphire viewport consists of a stainless steel flange, a bridge adaptor and a sapphire dielectric. Kovar is typically used as the material of bridge adaptor to form hermetic seals between SUS flange and sapphire dielectric. Besides, a prior surface metallization layer has to be applied on sapphire dielectric before it can be hermetically sealed with kovar adaptor by brazing. The metallization layer mainly contains Mo, Mn and Ni. Since both kovar and Ni are magnetic materials, they will distort spatial distribution of ambient magnetic field. This has to be taken into account if foregoing effect is critical to user's application with viewport.

Our sapphire viewport contains non-magnetic stainless steel, either 304 or 316, and sapphire dielectric only. Surface metallization layer on sapphire disk doesn't contain any magnetic composition. Proprietary technology of unmatched seal is used in brazing sapphire disk with stainless steel adaptor together, which in turn is tig-welded with stainless steel flange. Our offer of non-magnetic sapphire viewport is the solution if referred distortion of magnetic field by the existence of magnetic material can't be tolerated in user's application.

➤ KF Flange Sapphire Viewport

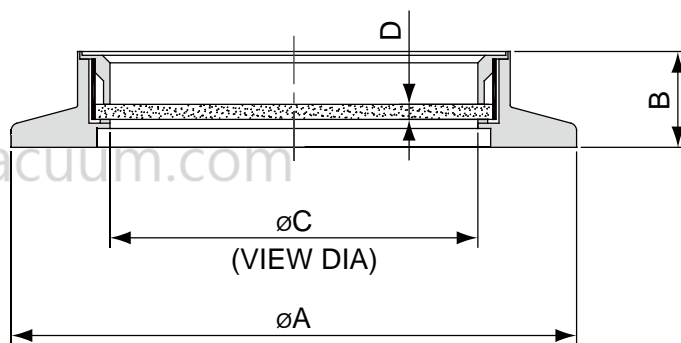

Model No.	Material	A	B	C	D	Flange	Parts No .
KVPS39	304 S.S. / Sapphire	55	12.7	38.5	2	KF40	1000V0A043
KVPS49	304 S.S. / Sapphire	75	12.7	48.8	2	KF50	1000V0A037

- Non-magnetic
- Excellent Surface Finish : 20-10 Scratch-Dig
- Broader Temperature & Transmission Range
- High Transparency & Wide Bandwidth
- High Hardness
- Customization Available Upon Request

Description	Description
Window Material	Sapphire
Flange Material	304 S.S. or 316 S.S.
Adapter	304 S.S. or 316 S.S.
Leak Rate	$<1 \times 10^{-10}$ mbar.l/sec
Temperature Range	-100°C to 450°C
Transmission rate/rang	>80% (0.2 μm ~4.8 μm)
Max Thermal Gradient	15°C/min

Transmission Curve

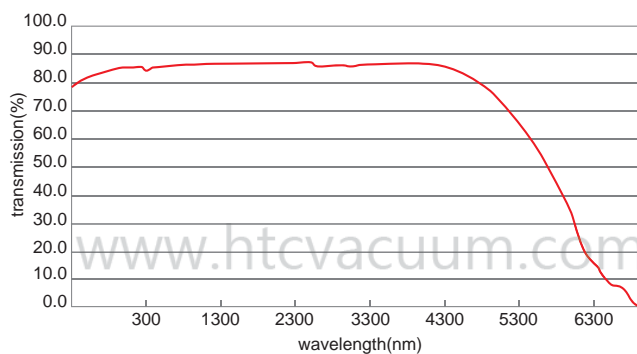

➔ KF Flange CaF2 Viewport

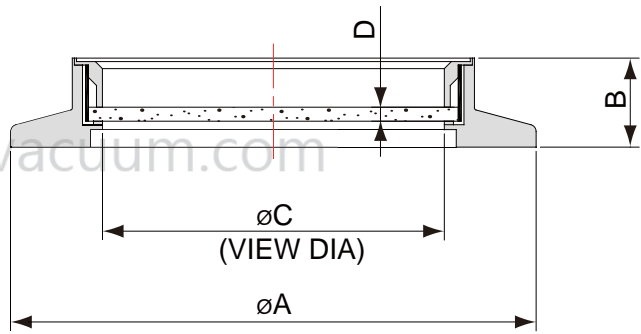

Model No.	A	B	C	D	Flange	Material	Parts No.
KVPC24	40	12.7	23.8	1.6	KF25	304S.S./CaF2	1000V0D001
KVPC39	55	12.7	38.5	2.7	KF40	304S.S./CaF2	1000V0D002

Description :

- Material of flange : 304S.S. or 316S.S. on customer demand
- Material of adaptor : 304S.S.
- Applicable vacuum range : 1×10^{-10} mbar
- (Practical vacuum range : contingent on customer 's O-ring)
- Applicable temperature range : -100°C to 200°C

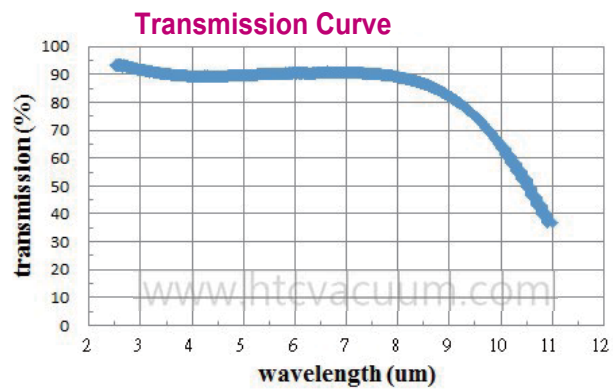

➔ CF Flange CaF2 Viewport

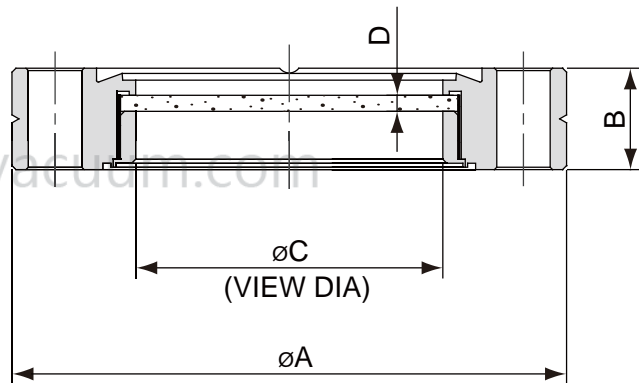

Model No.	A	B	C	D	Flange	Material	Parts No.
CVPC39	69.5	12.7	38.5	2.7	CF35	304S.S./CaF2	1000V0D003

Description :

- Material of flange : 304S.S. or 316S.S. on customer demand
- Material of adaptor : 304S.S.
- Applicable vacuum range : 1×10^{-10} mbar
- (Practical vacuum range : contingent on customer 's O-ring)
- Applicable temperature range : -100°C to 200°C

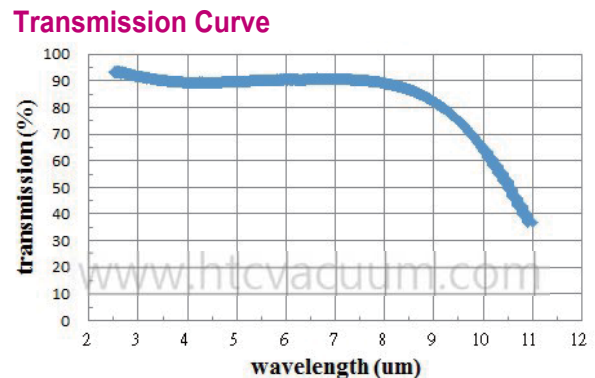

➤ KF Flange Tempered Glass Viewport

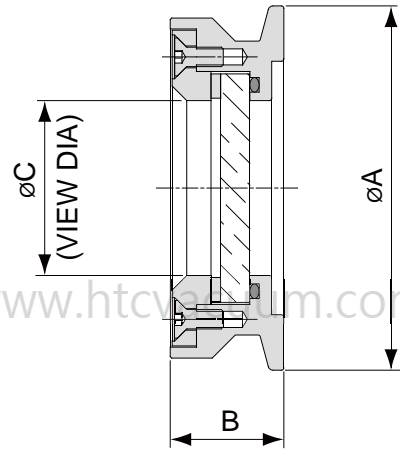

Model No.	A	B	C	Fits Flange	Parts No.
KF50VP	75	25	36	KF50	151A0600C

- Window Material : Tempered glass
- Body Material : 304S.S.
- Flange : KF
- Type of sealing : O-ring(Viton)
- Pressure Range : 1.2 bar~ 1×10^{-8} mbar
- Leak Rate : 1×10^{-9} mbar.l / sec
- Temperature Range : $-5^{\circ}\text{C} \sim 150^{\circ}\text{C}$

➤ ISO Flange Tempered Glass Viewport

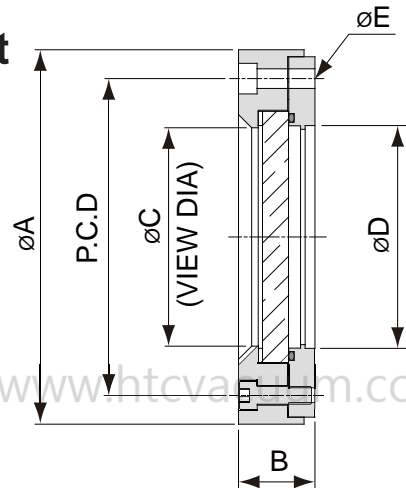

Model No.	A	B	C	D	E*No.	P.C.D.	Parts No.
ISO63VP	136.5	35	63	70	9*4	110	152A0700C
ISO100VP	171.4	35	98	102	9*8	145	152A0900C

- Window Material : Tempered glass
- Body Material : 304S.S.
- Flange : ISO
- Type of sealing : O-ring(Viton)
- Pressure Range : 1.2 bar~ 1×10^{-8} mbar
- Leak Rate : 1×10^{-9} mbar.l / sec
- Temperature Range : $-5^{\circ}\text{C} \sim 150^{\circ}\text{C}$



➤ Magnetic Fluid Feedthrough



Application

Htc vacuum provides quality magnetic fluid rotary feedthroughs, which introduces rotary motion into vacuum environments. A magnetic fluid rotary feedthrough is composed of a non-magnetic housing, bearings, pole pieces, a permanent magnet, a magnetic shaft and ferrofluid. When ferrofluid is applied to the gap between the shaft and the pole pieces in a rotary feedthrough, it creates a magnetic field which functions like an O-ring in the gap. Magnetic fluid rotary feedthroughs can be used in ultra-high vacuum systems and other critical equipment in Semiconductor, FPD, and Solar PV Industry.

Features

- **Long Service Life**
Non-contact seal, no mechanical friction, very low maintenance
- **High Vacuum Capability**
Low vapor pressure, used in vacuum range up to 10^{-8} mbar
- **High Speed Capability**
Very low particle occurs, capable of high speed
- **Wide Transfer Torque**
Various models are available according to application : from 5kg-cm up to over 5000kg-cm
- **Optimum Torque Transmission**
Very little torque lost, no backlash or stick-slip

Application

- Vacuum range : up to 10^{-8} mbar
- Leak rate(He) : $< 10^{-11}$ mbar.l/sec (He)
- Temperature : 0~80°C

Notice

- Prevent magnetic fluid rotary feedthrough from dust and organic solvents (alcohol, acetone, Freon, etc.)
- Do not load higher than 1kg/cm² in vacuum environment.
- When the shaft of magnetic fluid rotary feedthrough is at rest, it is normal that the vacuum pressure may rise after the shaft starts working. The situation can be avoided through advanced startup.
- For water cooling devices, the cooling water should be at 1-3kg/cm² at room temperature. Besides, water can not be left in the inner feedthrough which could cause rust and circumrotating failure.



Flange Mount, Solid Shaft

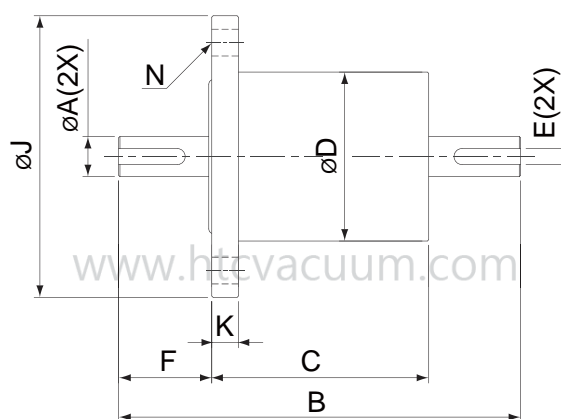

Model No.	A	B	C	D	E	F	J	K	N	Torque (kg-cm)	Parts No.
SF006	Ø6 ⁺⁰ _{-0.018}	97.5	57.5	38	0.5Dp*12Lg(Flat)	20	78	10	P.C.D.60/4-Ø10	9.2	1000FF011001
SF010	Ø10	119.5	69.5	44	3W*1.8Dp*14Lg	25	78	10	P.C.D.60/4-Ø10	59	1000FF011002
SF012	Ø12 ⁺⁰ _{-0.02}	133.5	73.5	48	4W*2.5Dp*20Lg	30	88	10	P.C.D.70/4-Ø10	118	1000FF011003
SF020	Ø20 ⁺⁰ _{-0.033}	151.5	81.5	63	6W*3.5Dp*25Lg	35	105	10	P.C.D.85/4-Ø10	585	1000FF011004
SF026	Ø25 ⁺⁰ _{-0.033}	173.5	93.5	75	8W*4Dp*30Lg	40	115	10	P.C.D.95/6-Ø10	1013	1000FF011005

- Degree vacuum pressure [mbar] : 1×10^{-8}
- Leakage rate(He) [mbar.l/sec] : $< 10^{-11}$
- Temperature range(°C) : 0~80°C (Adding water cooling structure if it is beyond this temperature range)

Nose Mount, Solid Shaft

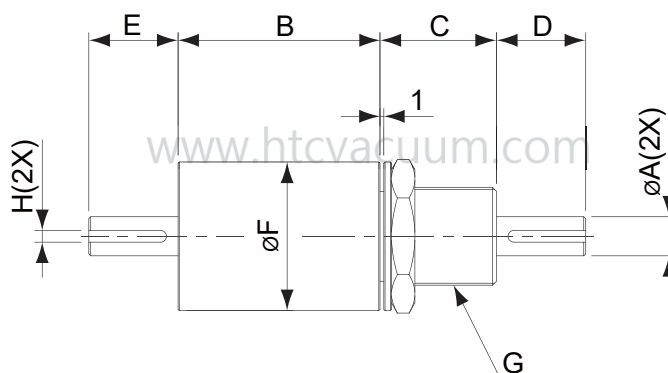

Model No.	A	B	C	D	E	F	G	H	Torque (kg-cm)	Parts No.
ST005	Ø5 ^{-0.010} _{-0.022}	32	6	12.5	15	16	M8xP1	-	9.2	1000FF012001
ST006	Ø6 ⁻⁰ _{-0.018}	42	10	15	15	28	M12xP1.25	0.5Dp*10Lg(Flat)	15.2	1000FF012002
ST010	Ø10 ^{-0.013} _{-0.028}	52	30	23	23	38	M25xP1.5	3W*1.8Dp*20Lg	76	1000FF012003
ST020	Ø20 ^{-0.020} _{-0.041}	60	34	36	36	54	M40xP1.5	6W*3.5Dp*32Lg	570	1000FF012004

- Degree vacuum pressure [mbar] : 1×10^{-8}
- Leakage rate(He) [mbar.l/sec] : $< 10^{-11}$
- Temperature range(°C) : 0~80°C (Adding water cooling structure if it is beyond this temperature range)



➤ Single Axle(shaft) Non Flange Ferrofluid Feedthrough

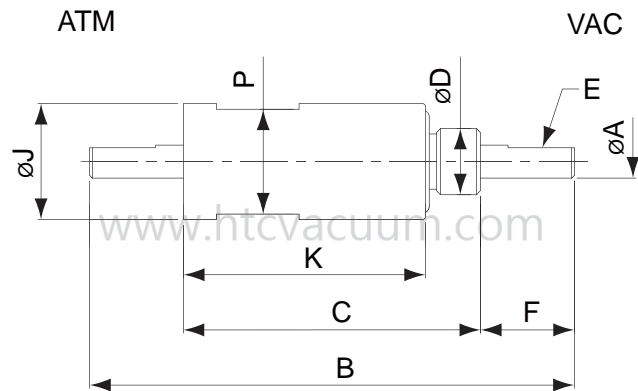

Model No.	ØA	B	C	D	E	F	ØJ	K	P	Parts No.
ASS0004CNR10	Ø4 ⁺⁰ _{-0.018}	76.5	46.5	M12*P1.5	0.5Dp*10Lg	15	21	36.5	19	1000FF050001
ASS0005CNR10	Ø5 ⁺⁰ _{-0.018}	76.5	46.5	M12*P1.5	0.5Dp*10Lg	15	21	36.5	19	1000FF050002
ASS0006CNR10	Ø6 ⁺⁰ _{-0.018}	76.5	46.5	M12*P1.5	0.5Dp*10Lg	15	21	36.5	19	1000FF050003

- Degree vacuum pressure [mbar] : 1×10^{-6}
- Leakage rate(He) [mbar.l/sec] : $< 10^{-12}$
- Temperature range(°C) : 0~80°C
- Applicable Gas : Inert Gas
- Housing Material : 304S.S.
- Shaft Material : 420S.S.

➤ Nut Bush Ferrofluid Vacuum Seal Axle Feedthrough

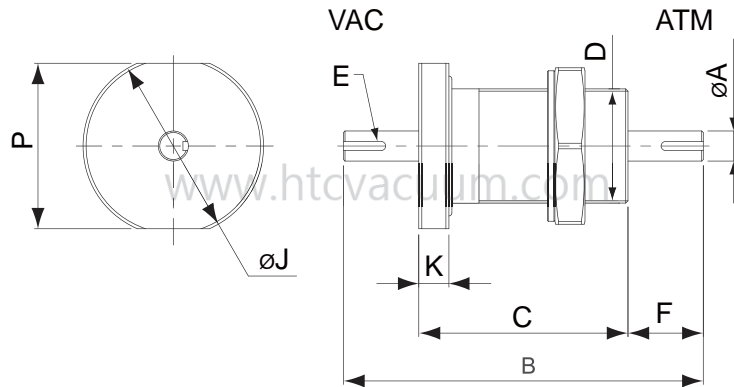

Model No.	ØA	B	C	D	E	F	ØJ	K	P	Parts No.
ABS0006CNR10	Ø6 ⁺⁰ _{-0.018}	97.5	57.5	M32*P1.5	0.5Dp*12Lg(Flat)	20	55	10	-	1000FF051001
ABS0010CNR10	Ø10 ⁺⁰ _{-0.018}	119.5	69.5	M38*P1.5	3W*1.8Dp*14Lg	25	60	10	55	1000FF051002
ABS0012CNR10	Ø12 ⁺⁰ _{-0.018}	119.5	69.5	M38*P1.5	3W*1.8Dp*14Lg	25	60	10	55	1000FF051003

- Degree vacuum pressure [mbar] : 1×10^{-6}
- Leakage rate(He) [mbar.l/sec] : $< 10^{-12}$
- Temperature range(°C) : 0~80°C
- Applicable Gas : Inert Gas
- Housing Material : 304S.S.
- Shaft Material : 420S.S.



➤ Semiconductor Sealed Spindles

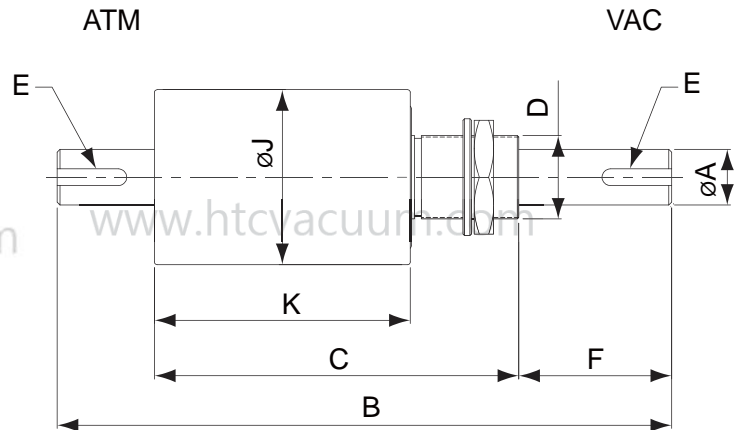

Model No.	ØA	B	C	D	E	F	ØJ	K	Parts No.
ANS0012CNR10	Ø12 ⁺⁰ _{-0.027}	179	109	M25*P1.5	4W*2.5Dp*20Lg	40	48	74	1000FF052001
ANS0020CNR10	Ø20 ⁺⁰ _{-0.033}	211	121	M30*P1.5	6W*3.5Dp*25Lg	55	63	82	1000FF052002

- Degree vacuum pressure [mbar] : 1×10^{-6}
- Leakage rate(He) [mbar.l/sec] : $< 10^{-12}$
- Temperature range(°C) : 0~80°C
- Applicable Gas : Inert Gas
- Housing Material : 304S.S.
- Shaft Material : 420S.S.

➤ Semiconductor Sealed Spindles

With Water Cooling

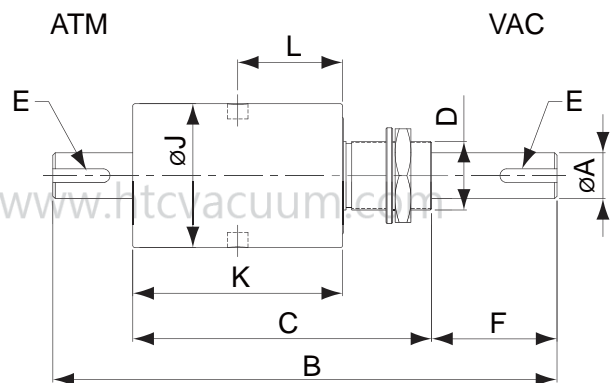

Model No.	ØA	B	C	D	E	F	ØJ	K	L	Parts No.
ANS0012WNR10	Ø12 ⁺⁰ _{-0.027}	179	109	M25*P1.5	4W*2.5Dp*20Lg	40	48	74	36.5	1000FF053001
ANS0020WNR10	Ø20 ⁺⁰ _{-0.033}	211	121	M30*P1.5	6W*3.5Dp*25Lg	55	63	82	40.5	1000FF053002

- Degree vacuum pressure [mbar] : 1×10^{-6}
- Leakage rate(He) [mbar.l/sec] : $< 10^{-12}$
- Temperature range(°C) : 0~80°C
- Applicable Gas : Inert Gas
- Housing Material : 304S.S.
- Shaft Material : 420S.S.



→ Hollow Axle Magnetic Fluid Feedthrough

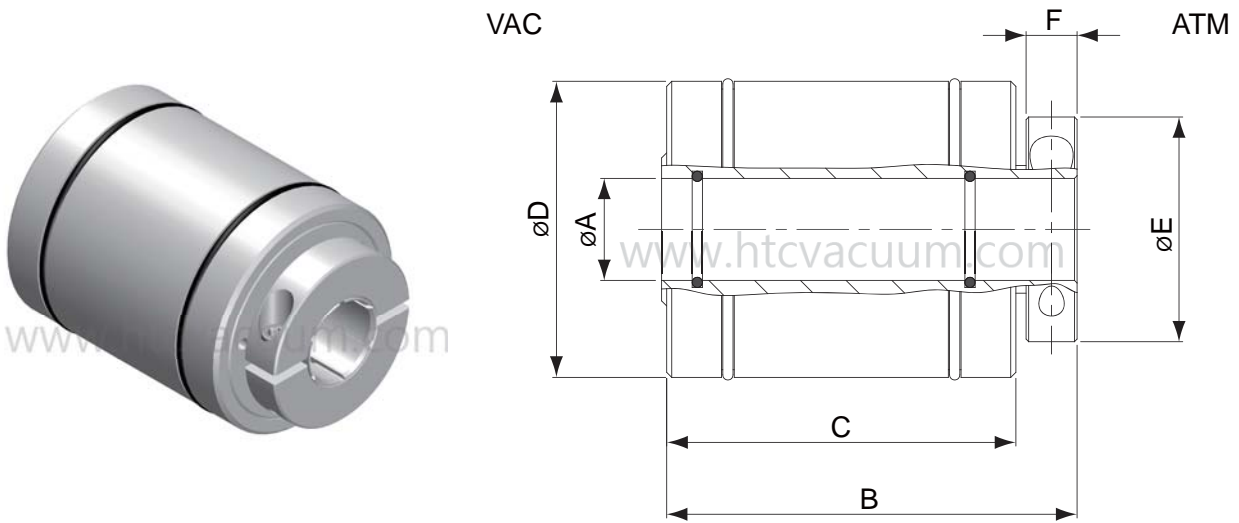

Model No.	ØA	B	C	ØD	ØE	F	Parts No.
ACM0010CNR10	Ø10 ^{+0.03} / _{+0.01}	78	64	48 ⁺⁰ / _{-0.02}	34	10	1000FF054001
ACM0020CNR10	Ø20 ^{+0.04} / _{+0.02}	82.5	68.5	58 ⁺⁰ / _{-0.03}	44	10	1000FF054002
ACM0025CNR10	Ø25 ^{+0.04} / _{+0.02}	88	74	63 ⁺⁰ / _{-0.03}	49	10	1000FF054003
ACM0030CNR10	Ø30 ^{+0.04} / _{+0.02}	93	79	73 ⁺⁰ / _{-0.03}	54	10	1000FF054004
ACM0040CNR10	Ø40 ^{+0.05} / _{+0.02}	96	80	88 ⁺⁰ / _{-0.04}	69	12	1000FF054005
ACM0050CNR10	Ø50 ^{+0.05} / _{+0.02}	98	82	98 ⁺⁰ / _{-0.04}	79	12	1000FF054006
ACM0075CNR10	Ø75 ^{+0.06} / _{+0.03}	115	96	137 ⁺⁰ / _{-0.04}	109	15	1000FF054007

- Degree vacuum pressure [mbar] : 1×10^{-6}
- Leakage rate(He) [mbar.l/sec] : $< 10^{-12}$
- Temperature range(°C) : 0~80°C
- Applicable Gas : Inert Gas
- Housing Material : 304S.S.
- Shaft Material : 420S.S.

➤ Hollow Axle Flanged Ferrofluid Feedthrough

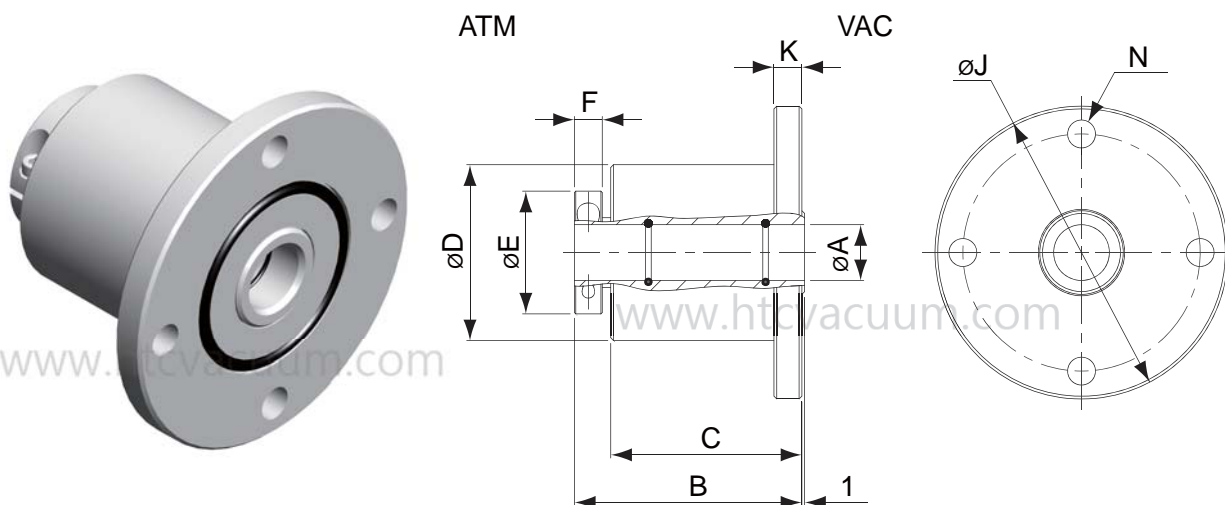

Model No.	ØA	B	C	ØD	ØE	F	ØJ	N	Parts No.
AFM0010CNR10	Ø10 ^{+0.03} / _{+0.01}	78	64	51	34	10	90	P.C.D.70/4-Ø10	1000FF055001
AFM0020CNR10	Ø20 ^{+0.04} / _{+0.02}	82.5	68.5	63	44	10	105	P.C.D.85/4-Ø10	1000FF055002
AFM0025CNR10	Ø25 ^{+0.04} / _{+0.02}	88	74	71	49	10	120	P.C.D.100/4-Ø10	1000FF055003
AFM0030CNR10	Ø30 ^{+0.04} / _{+0.02}	93	79	78	54	10	120	P.C.D.100/4-Ø10	1000FF055004
AFM0040CNR10	Ø40 ^{+0.05} / _{+0.02}	96	80	90	69	12	145	P.C.D.120/4-Ø12	1000FF055005
AFM0050CNR10	Ø50 ^{+0.05} / _{+0.02}	98	82	103	79	12	160	P.C.D.135/4-Ø12	1000FF055006
AFM0075CNR10	Ø75 ^{+0.06} / _{+0.03}	115	96	143	109	15	210	P.C.D.185/8-Ø12	1000FF055007

- Degree vacuum pressure [mbar] : $1 \cdot 10^{-6}$
- Leakage rate(He) [mbar.l/sec] : $< 10^{-12}$
- Temperature range(°C) : 0~80°C
- Applicable Gas : Inert Gas
- Housing Material : 304S.S.
- Shaft Material : 420S.S.

➔ Hollow Axle Flanged Ferrofluid Feedthrough

With Water Cooling

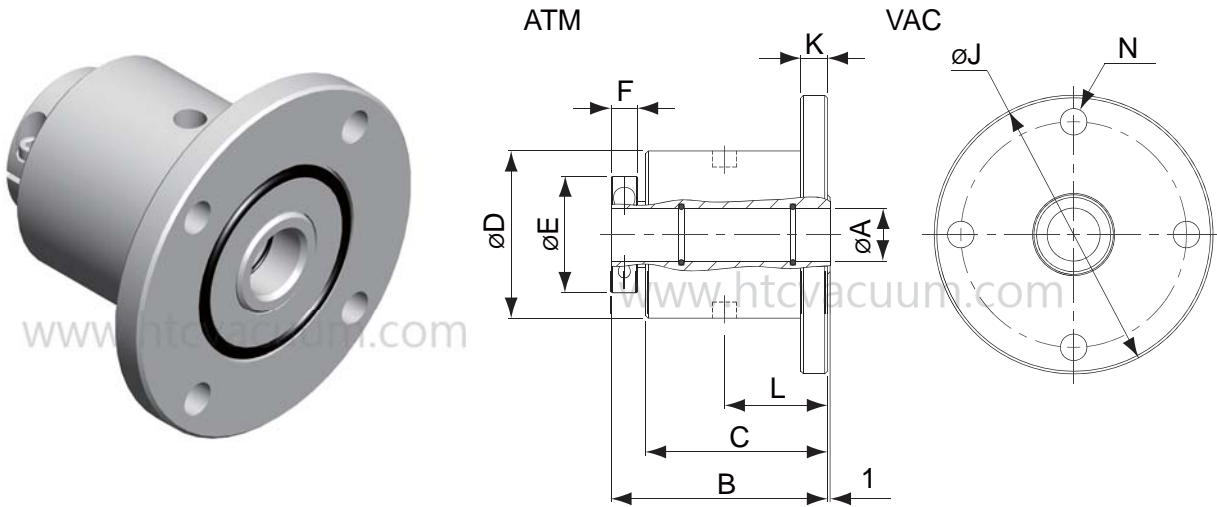

Model No.	ØA	B	C	ØD	ØE	F	ØJ	N	Parts No.
AFM0010WNR10	Ø10 ^{+0.03} / _{+0.01}	78	64	51	34	10	90	P.C.D.70/4-Ø10	1000FF056001
AFM0020WNR10	Ø20 ^{+0.04} / _{+0.02}	82.5	68.5	63	44	10	105	P.C.D.85/4-Ø10	1000FF056002
AFM0025WNR10	Ø25 ^{+0.04} / _{+0.02}	88	74	71	49	10	120	P.C.D.100/4-Ø10	1000FF056003
AFM0030WNR10	Ø30 ^{+0.04} / _{+0.02}	93	79	78	54	10	120	P.C.D.100/4-Ø10	1000FF056004
AFM0040WNR10	Ø40 ^{+0.05} / _{+0.02}	96	80	90	69	12	145	P.C.D.120/4-Ø12	1000FF056005
AFM0050WNR10	Ø50 ^{+0.05} / _{+0.02}	98	82	103	79	12	160	P.C.D.135/4-Ø12	1000FF056006
AFM0075WNR10	Ø75 ^{+0.06} / _{+0.03}	115	96	143	109	15	210	P.C.D.185/8-Ø12	1000FF056007

- Degree vacuum pressure [mbar] : 1×10^{-6}
- Leakage rate(He) [mbar.l/sec] : $< 10^{-12}$
- Temperature range(°C) : 0~80°C
- Applicable Gas : Inert Gas
- Housing Material : 304S.S.
- Shaft Material : 420S.S.

➤ Molecular Sieve

The zeolite inside the tank trap the oil vapor that back stream toward the vacuum chamber from mechanical pump, and trap other gases include water vapor from chamber toward the mechanical pump.

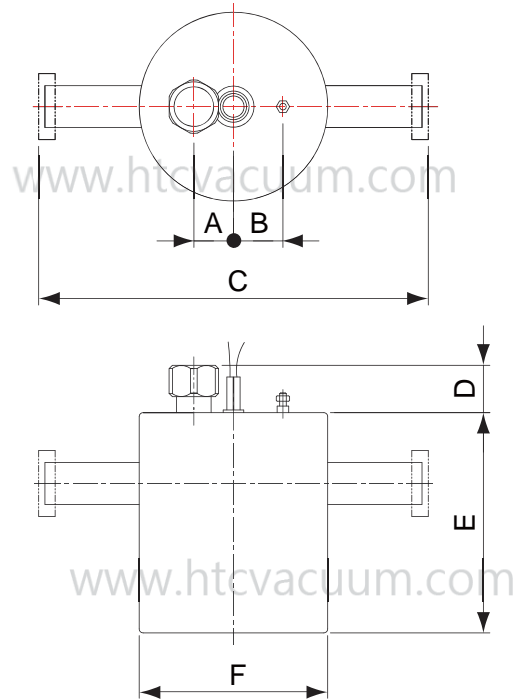

Model No.	O.D.	A	B	C	D	E	F	Parts No.
MST-KF16	19.1	24	30	236.2	28.7	133.4	Ø114.3	1000H0B010
MST-KF25	25.4	24	30	236.2	28.7	133.4	Ø114.3	1000H0B003
MST-KF40	38.1	24	30	236.2	28.7	200	Ø114.3	1000H0B004
MST-CF35	38.1	24	30	239.2	28.7	200	Ø114.3	1000H0B012

- Trap body : 304S.S.
- Power : AC110 , 300V
- Sieve material : zeolite
- Zeolite type : 13x4mm (pellet size)
- Zeolite capacity : KF16/KF25(0.5kg)
KF40/CF35(0.7kg)

➔ Inline LN₂ Cold Trap

A cold trap is equipped at pumping line between chamber and pump. The cold trap can trap the volatile material to prevent they enter the mechanical pump and trap the oil from mechanical pump to prevent they enter the chamber.

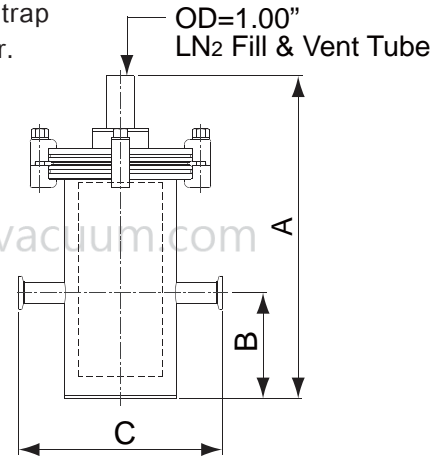
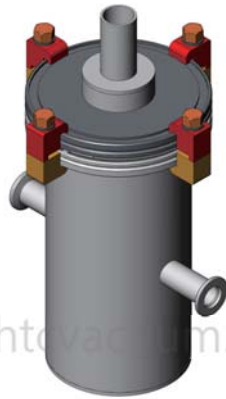

Model No.	Flange size	LN ₂ Volume (liters)	A	B	C	Parts No.
KF16LN2CT	KF16	0.7	290	95	185	1000H0P001
KF25LN2CT	KF25	0.7	290	95	185	1000H0P002
KF40LN2CTS	KF40	0.7	290	95	185	1000H0P003
KF40LN2CT	KF40	1.6	360	115	235	1000H0P004
KF50LN2CT	KF50	1.6	360	115	235	1000H0P005

Refill time table for single tube LN₂ traps

Trap diameter (Inch)	LN ₂ Volume (liters)	Hours
4	0.7	8
6	1.6	12

➔ Exhaust Filter

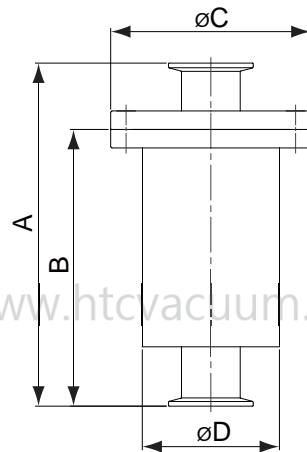

Model No.	A	B	C	D	Connector	Filter Material	Filter Pore Size	Parts No.
EFT-KF25-PP	222.5	179.5	130	89	KF25	PP	0.3	ZZE039A0030100
EFT-KF40-PP	222.5	179.5	130	89	KF40	PP	0.3	ZZE039A0020100
EFT-KF25NWF	222.5	179.5	130	89	KF25	non-woven fabric	25	ZZE115A0010100
EFT-KF40NWF	222.5	179.5	130	89	KF40	non-woven fabric	25	ZZE004A0050100
EFT-KF40-SS	222.5	179.5	174	133	KF40	stainless shavings	N/A	ZZE135A0010100

- Body material : 304S.S.

